

**46W LED  
Tasklight provides  
as much light as  
100W HID and  
lasts 7 times  
longer**

# LED Tasklight

Targeted illumination in Class I, Division 2 applications

**COOPER** Crouse-Hinds



Cooper Crouse-Hinds LED Tasklight is designed for the targeted illumination of equipment and pathways in hazardous locations where general room or area lighting is insufficient or has been reduced to conserve energy.

The LED Tasklight delivers up to 60,000 hours of white light in a corrosion resistant and watertight package, offering years of maintenance-free operation. This compact fixture delivers light output similar to many lower wattage HID fixtures at a fraction of the energy, resulting in reduced operating costs.

# LED Tasklight for Targeted Illumination



LED technology is an integral part of Cooper Crouse-Hinds plan to broaden customer solutions and drive innovation throughout all of our markets.



## FEATURES & BENEFITS

- LED Technology improves system performance and lowers costs over the life of the luminaire
- Up to 60,000 hours of bright LED white light for areas that require constant illumination. Maintains 70% lumen output through luminaire life
- Low power consumption < 50W
- Instant illumination and restrike for improved safety and productivity
- Crisp white light improves visibility of signs, instrument panels and equipment
- Cold temperature operation with no warm-up required for increased safety
- Extremely durable and vibration resistant for demanding environments
- Environmentally friendly - contains no hazardous substance such as mercury

## CERTIFICATIONS & COMPLIANCES

Certified by ETL to the following standards:

- UL 844, UL 1598A
- Class I, Div. 2, Groups A, B, C, D
- CSA C22.2 No 137
- Marine & wet locations
- Enclosure Type 3, 3R, 4, 4X; IP 66



## APPLICATIONS

- Tanks
- Instrument panels
- Switch racks
- Storage areas
- Motors/Generators
- Pathways
- Security areas

## ORDERING INFORMATION

Catalog Number	Lumen Maintenance	Watts	Input Voltage/ Input Current 50/60 Hz	Power Factor	Light Output	Temperature Performance	Operating Temp. Range
TX2LW/120/240	70% at 60k hrs	46	120 / 0.4 A 240 / 0.2 A	> 0.9	3267 Lm	T4A at 55°C	-40°C to 55°C* -25°C to 55°C

\* UL test range

Mounting Height (ft)	Peak	A	B	C	D	E
4	88.00	60.00	40.00	32.00	20.00	12.00
8	22.00	15.00	10.00	8.00	5.00	3.00
12	9.78	6.67	4.44	3.56	2.22	1.33
16	5.50	3.75	2.50	2.00	1.25	0.75
20	3.52	2.40	1.60	1.28	0.80	0.48
25	2.25	1.54	1.02	0.82	0.51	0.31
30	1.56	1.07	0.71	0.57	0.36	0.21
35	1.15	0.78	0.52	0.42	0.26	0.16

Footcandle Values for Isofootcandle Lines

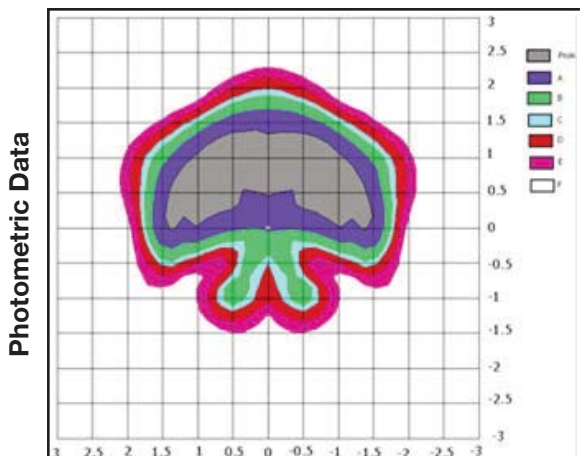

Photometric Data

## Dimensions and Weights

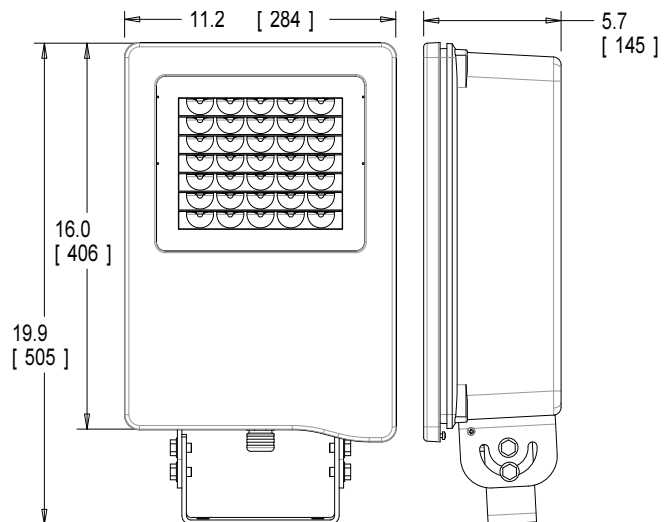

Weight - 25 lbs.

Cooper Crouse-Hinds  
P.O. Box 4999  
Syracuse, NY 13221-4999  
P: 315-477-7000  
www.crouse-hinds.com